

EXTRUSION FIXING

Contact 926mm Island Unit Extrusion Fixing

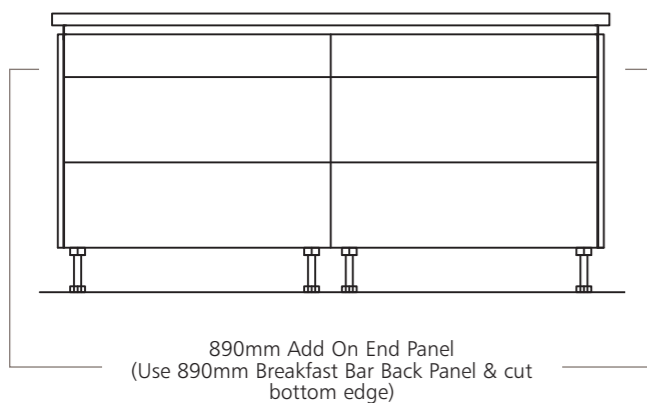

Contact 632mm Island Unit Extrusion Fitting

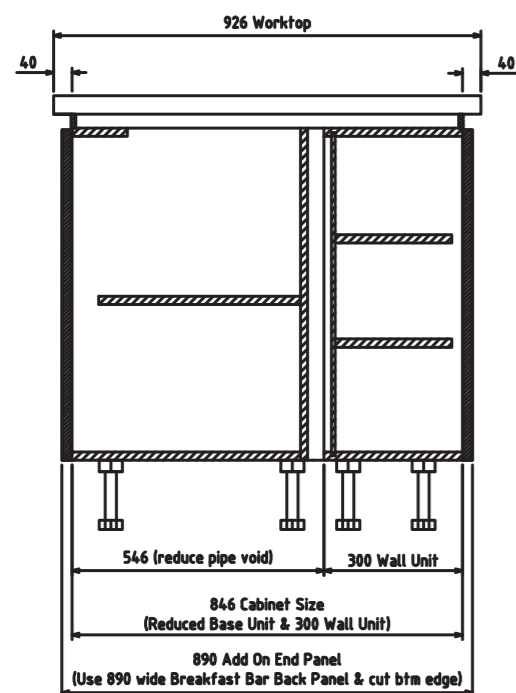
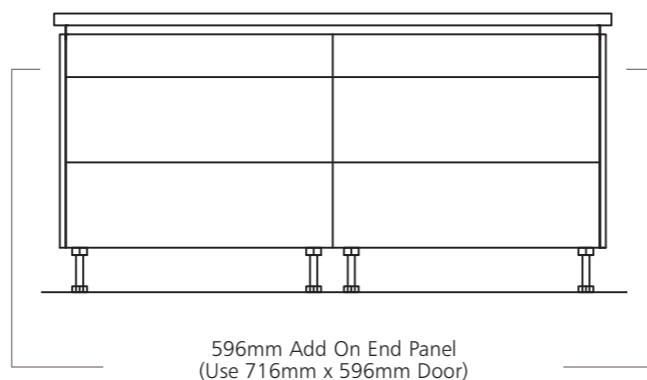
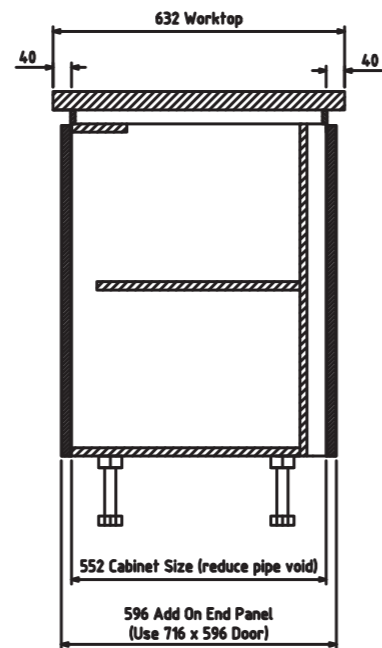

Standard Height Base & Wall Units

BEFORE ORDERING PLEASE NOTE:

75% of all kitchens ordered have insufficient quantities of plinth, cornice/pelmet and accessory panels. Please double check your requirements allowing sufficient extra lengths to cover joints, mitres, shapings etc. Failure to do so may delay your installation.

KEY

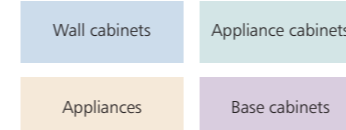

NOTE:

Measurements are in millimetres.

Not all units shown are available in every range.

Inside stacked wall units and bridging units under cupboard lights should be used instead of low voltage downlights.

(ii) Not available in:
Verve Ivory
Pure White
Gloss Walnut & Natural Oak
Arc Walnut & Natural Oak
Cosmopolitan
Technica Gloss Ivory
Technica Gloss Black

(iii) Not available in:
Arc Natural Oak and Walnut,
Futura Gloss White and Buttermilk
Verve Maple, Beech
T Bar Buttermilk
Cotswold Oak
Maplewood Shaker
Planked Buttermilk
Farmhouse Buttermilk

(iv) Not available in:
Pure White
Hilton Ivory
Walnut Wood Shaker
Technica Gloss Ivory
Technica Gloss Black
Gloss Walnut & Gloss Natural Oak

(v) Not available in:
Technica Gloss Ivory
Technica Gloss Black
Farmhouse Buttermilk
Verve Lissa Oak
Lissa Oak Wood Shaker
Arc Natural Oak
Arc Walnut

(+) Available in:
Futura
Technica Gloss Ivory
Technica Gloss Stone
Technica Gloss White
Pure White

(v) Available in:
Futura
Technica Gloss Ivory
Technica Gloss Stone
Technica Gloss White
Pure White
Gloss Walnut
Gloss Natural Oak

(+) Available in:
Futura
Verve Buttermilk
Gloss Walnut & Natural Oak
Verve Ivory
Technica Gloss Ivory, Stone & White
Pure White
Verve Lissa Oak
Shaker Gloss Stone
Georgian Buttermilk
Hilton Ivory
Lissa Oak Wood Shaker
Naturalwood Shaker Oak

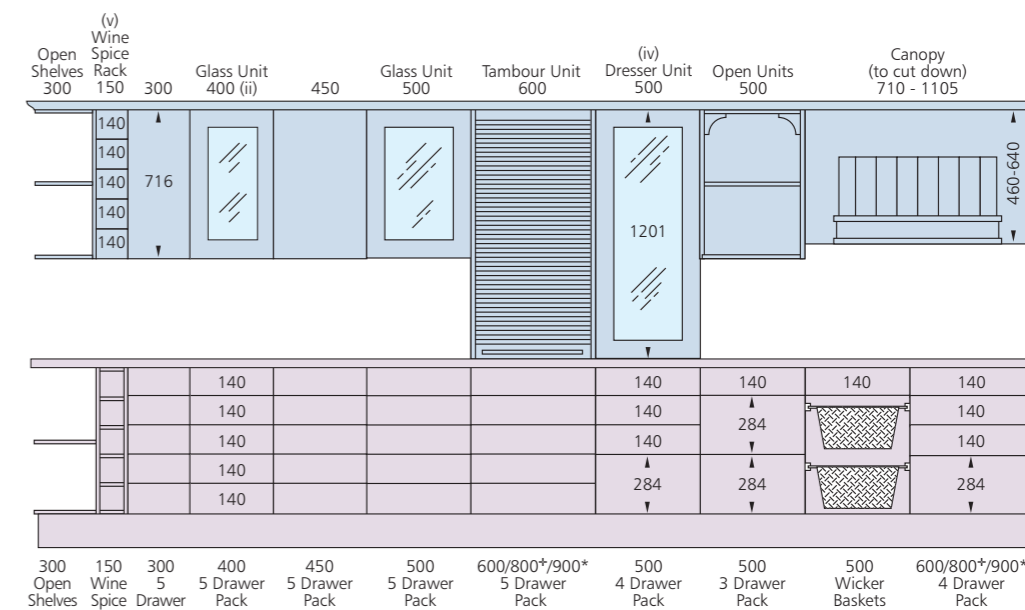
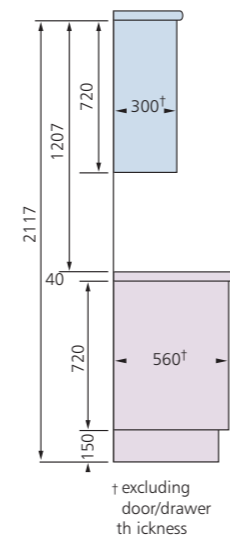

*Not available in T Bar Buttermilk

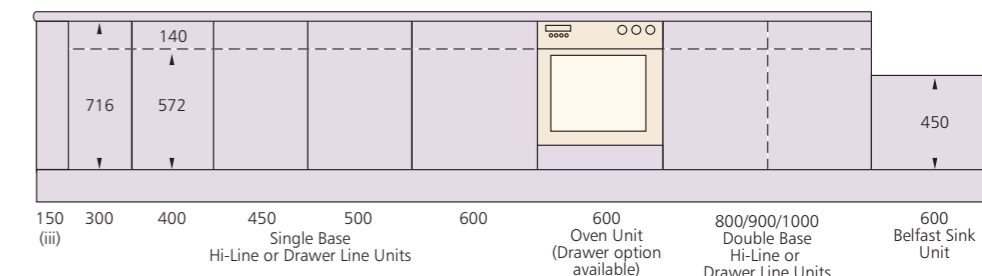
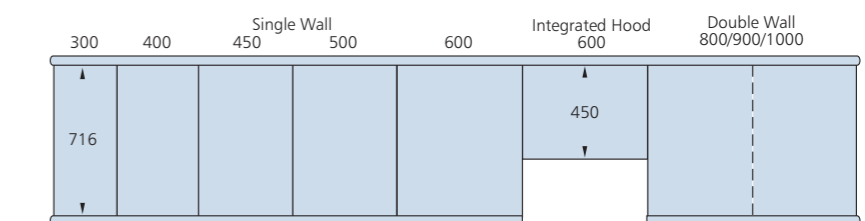
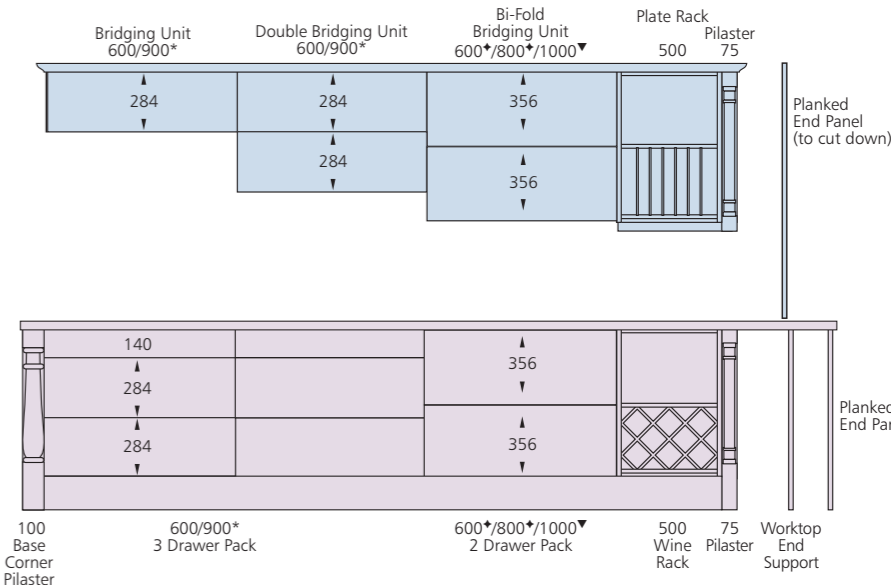

TECHNICAL SPECIFICATIONS

Tall Appliance range content (See fascia matrix on page 28 for range restrictions)

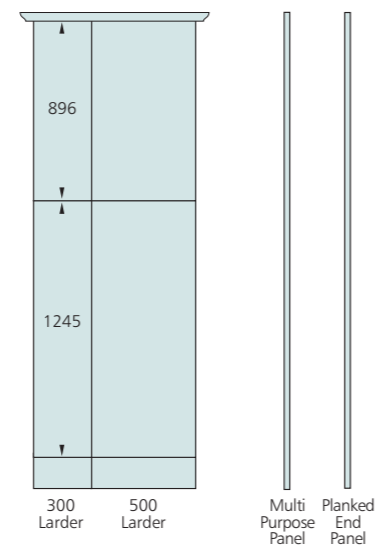
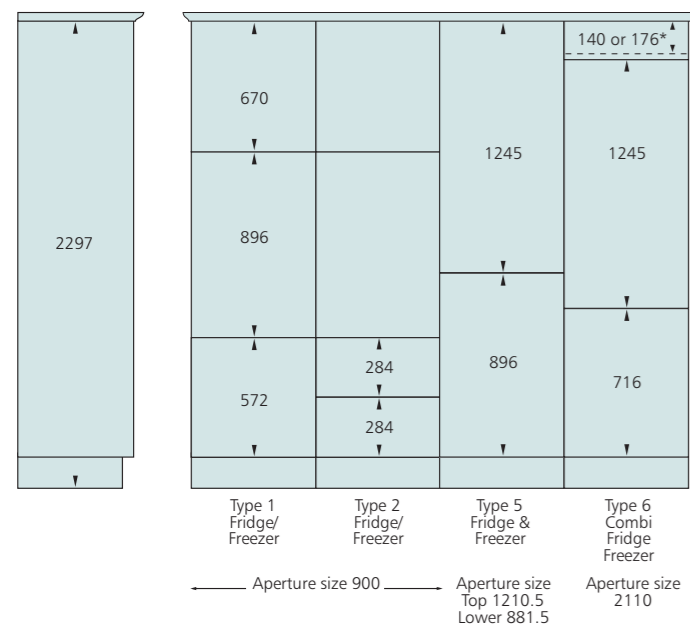
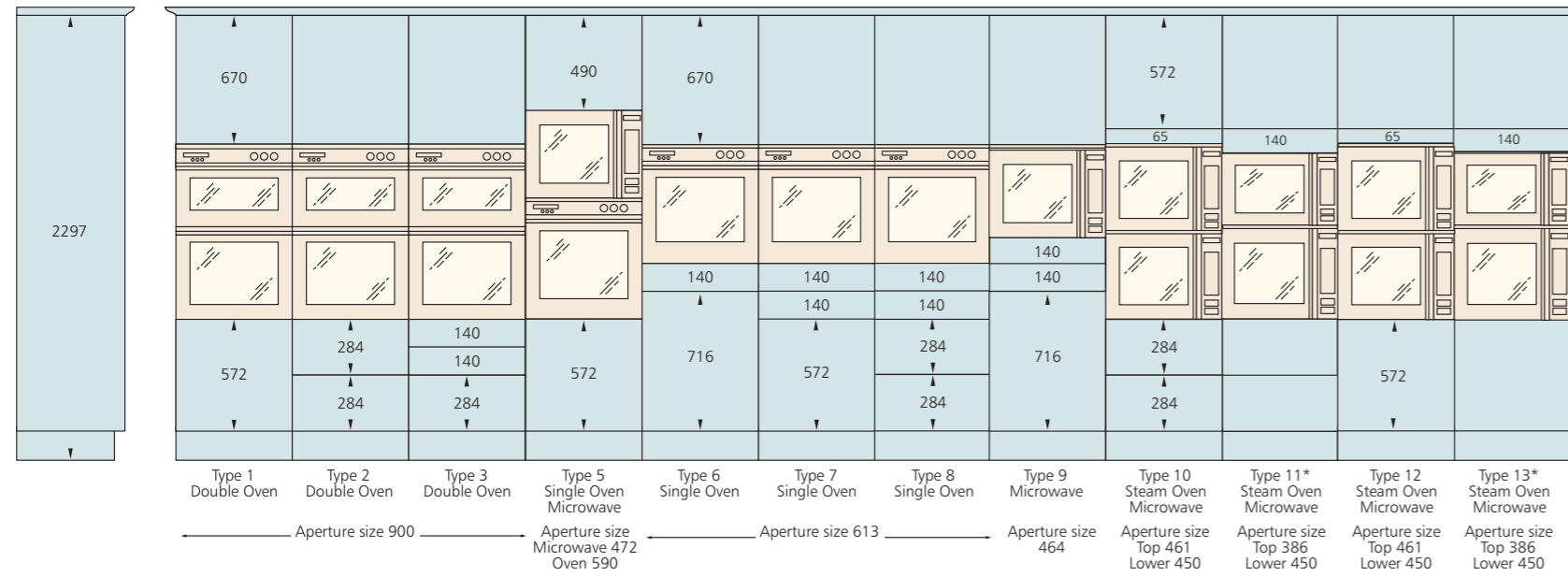

KITCHEN MATERIAL SPECIFICATIONS

RANGE NAME	MATERIAL	RANGE NAME	MATERIAL
Regent Platinum White	PVC foil laminated on MDF	Saponetta Gloss White, Buttermilk Matt, Beech, Maple Satin	PVC foil laminated on MDF
Verve Buttermilk	PVC foil laminated on MDF	Arc Natural Oak	Laminated particle board with PVC edging on two edges
Regent Buttermilk	PVC foil laminated on MDF	Gloss Natural Oak	Lacquered finish on MFC with PVC edging
Shires Oak	Solid Oak frame with Oak veneered centre panel	Planked Buttermilk	PVC foil laminated on MDF
Georgian Buttermilk	Lacquered finish on MDF	T Bar Panelled Buttermilk	PVC foil laminated on MDF
Gloss Burgundy Accent	PVC foil laminated on MDF	Verve Lissa Oak	Laminated MDF frame and centre panel
Shaker Gloss Stone	PVC foil laminated on MDF	Lissa Oak Wood Shaker	Solid oak frame with oak veneered centre panel
Shaker Gloss White	PVC foil laminated on MDF	Verve Maple, Beech	Laminated MDF frames with melamine faced particle board centre panel
Gloss Zebrano Accent	PVC foil laminated on MDF	Verve Maplewood	Solid Maple frame with Maple veneered centre panel
Georgian Platinum White	Lacquered finish on MDF	Verve Natural Oak	Laminated MDF frame and centre panel
Cosmopolitan	PVC foil laminated on MDF	Naturalwood Shaker	Solid Oak frame with Oak veneered centre panel
Technica Gloss Stone	PVC foil laminated on MDF	Verve Walnut	Laminated MDF frame and centre panel
Technica Gloss White	PVC foil laminated on MDF	Cotswold Oak	Solid Oak frame with Oak veneered centre panel
Technica Gloss Ivory	PVC foil laminated on MDF	Gloss Walnut	Lacquered finish on MFC with PVC edging
Technica Gloss Black	PVC foil laminated on MDF	Arc Walnut	Laminated particle board with PVC edging on two edges
Futura (all colours)	Melamine faced particle board with 2mm PVC edging	Walnutwood Shaker	Solid timber frame with walnut veneer and veneer centre panel
Farmhouse Buttermilk	Dual layered PVC laminated on MDF, handrubbed	Pure White	PVC foil laminated on MDF
Hilton Ivory	Solid ash frame with ash centre panel		
Verve Ivory	Laminated MDF frame and centre panel painted		

KITCHEN CHARACTERISTICS

Wood is a natural material with an endless variety of texture and grain. Variations are natural and whilst they may be evident on installation should diminish over a period of time to create a pleasant uniformity. Particular characteristics include random selection of grain and colour within doors.

CHIPPENDALE



Chippendale kitchens are manufactured in a modern, purpose built factory containing state of the art kitchen production technology. Based in South Yorkshire, Chippendale kitchens are proud of both their British heritage and a reputation of producing thoroughly modern kitchens with the very latest innovations, designs and features. With an extensive amount of finishing touches, every kitchen can be tailored to your taste and lifestyle. Also, don't forget Chippendale's personal deposit guarantee to you, a unique scheme which reflects Chippendale's philosophy of putting you, the customer, first. Although every Chippendale kitchen is designed to your taste and requirements, you can only gain a flavour of the quality and beauty by visiting an approved Chippendale studio.

Chippendale was honoured to receive visits from HRH Princess Margaret when she officially opened our new factory complex and HRH Princess Anne, The Princess Royal, when she visited the purpose built 315,000 sq ft factory and showrooms as part of the inauguration of Capitol Park in Doncaster where the Chippendale factory is located.