

GLAZED DOORS - All supplied with clear glass except Aluminum Frame (screen printed)

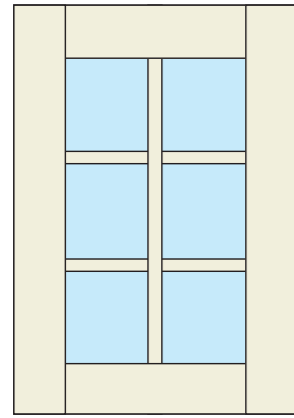

Verve Maple

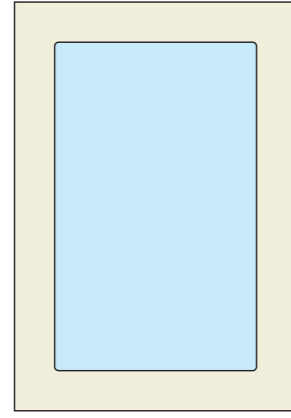

Technica Gloss White, Gloss Stone, Shaker Gloss Stone & Gloss White

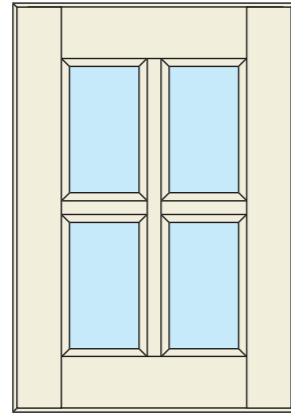

Cotswold Oak

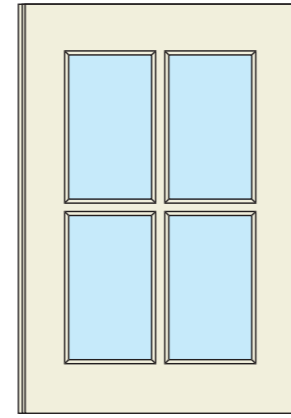

T Bar Buttermilk

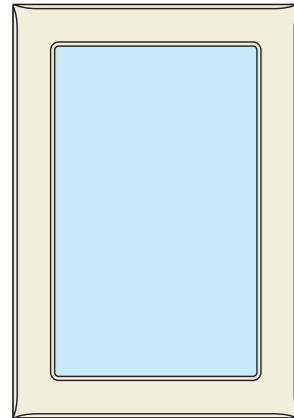

Saponetta

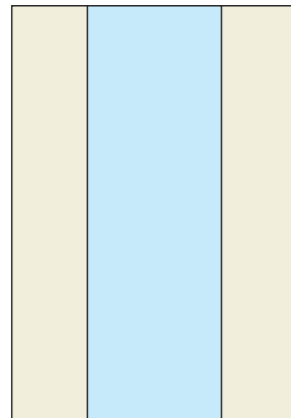

Futura, Arc Natural Oak, Arc Walnut

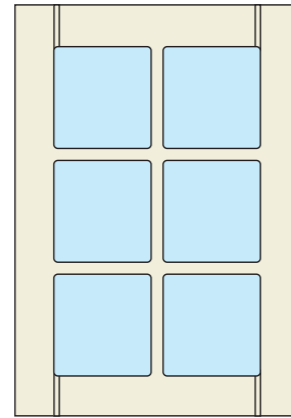

Cosmopolitan

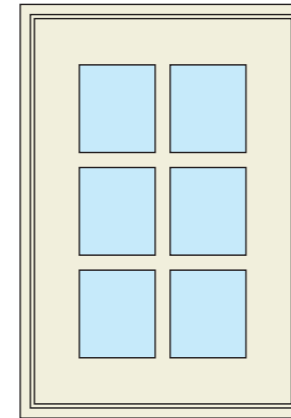

Georgian Buttermilk
Georgian Platinum White

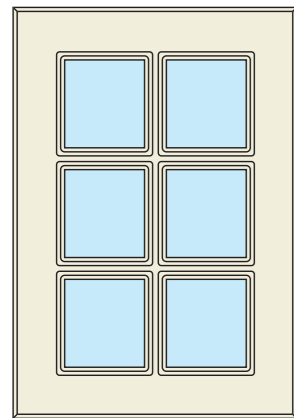

Regent Buttermilk
Regent Platinum White

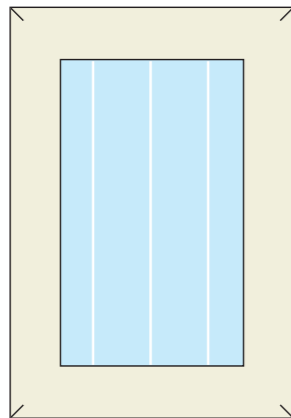

Planked Buttermilk, Farmhouse Buttermilk. Glass supplied with Brill cut.

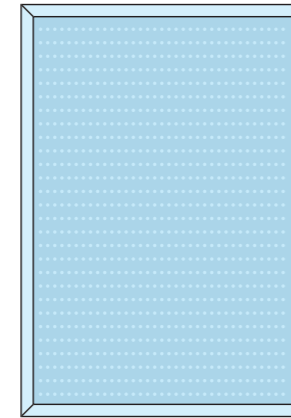

Aluminium Frame - Gloss Walnut & Natural Oak, Futura, Technica Gloss Ivory & Black & all other ranges

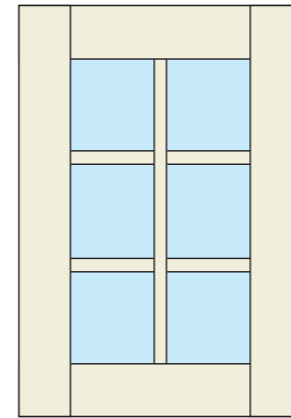

Maplewood Shaker

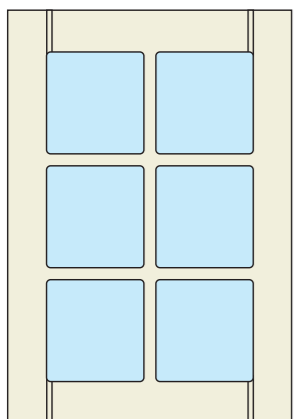

Shires Oak

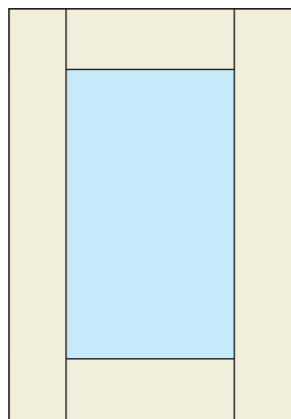

Verve Beech, Verve Natural Oak, Naturalwood Shaker, Verve Walnut, Lissa Oak & Verve Buttermilk

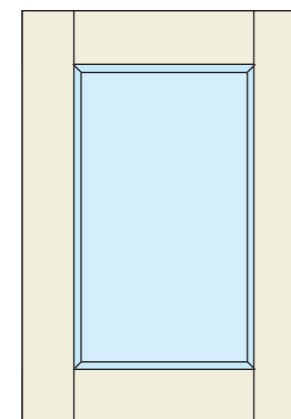

Hilton Ivory

CHIPPENDALE CONTACT

HANDLELESS KITCHENS

Chippendale 'Contact'

The Chippendale 'Contact' system is designed to make the planning and installation of a handleless kitchen as simple and straightforward as possible. Some basic principles are covered in this technical section and a full installation and adjustment leaflet will be supplied with each Chippendale 'Contact' kitchen.

The principle of 'Contact' is that wherever possible, doors and flaps are opened simply by touch which will activate the opening mechanism.

(Please note that certain appliance doors, pull-out units, magic corner units, etc are not available with this touch open system. The following pages will demonstrate the various options for designing a 'Contact' kitchen with these units).

In the same way, 'Contact' drawers and pan drawers are opened by simply pressing on the drawer to activate the spring open runners.

(Please note that certain drawers used on pull-out units are not available with spring open drawer runners. Internal drawers are not available with spring open runners).

A surcharge of £34 per drawer applies. Units that are affected by this are identified in the Price List by ★.

You will automatically receive the full quantity of 'contact' mechanisms to match your order. Additional 'contact' mechanisms can also be purchased, please refer to page 19.

Chippendale 'Contact' is available on all Futura and Technica doors. Also available in Walnut Gloss, Natural Oak Gloss and Pure White.

Please ensure you specify 'Contact' on your order.



Handle Options For Appliance Housings/Fascias, Pull-Out Units and Magic Corner Units

Any units that require a handle, such as appliance housings, appliance fascias, pull-out units and magic corner units, are clearly marked in the Price List with the following symbols:

- ❖ Select from handle suite 84 (for use with aluminium extrusions) or face fixed handle suites 2, 73, 78
- ◆ Select from face fixed handle suites 2, 73, 78
- ▲ When using the aluminium extrusion under the worktops, the conventional corner unit must use a variable corner post. The post will be supplied in the form of a 716x146mm fascia and will require cutting to fit on site. *Please add 'CN' to the end of the code to order in 'Contact'.*

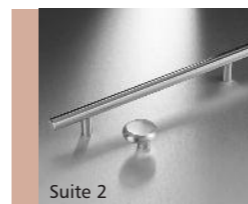

Suite 2



Suite 73



Suite 78

Suite 84 has been specifically designed to work with 'Contact' kitchens when aluminium extrusions are used.

This handle can be fitted simply, on-site, and enables the individual to pull open the units specified above, whilst not intruding on the handlefree design.

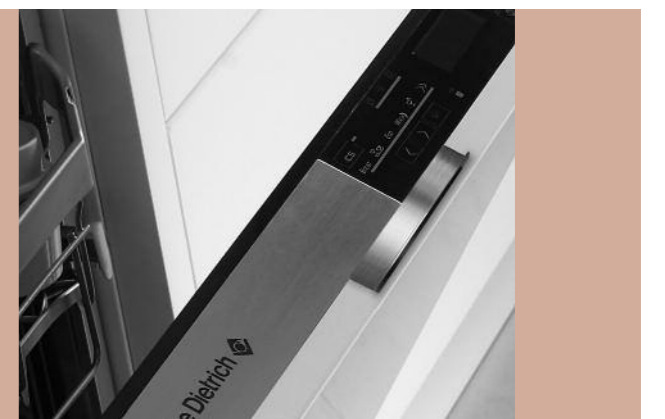

CHIPPENDALE CONTACT

Option 1 - Free-Standing Appliances

The simplest way of designing a Contact kitchen is to use free-standing appliances whilst avoiding certain units – e.g. pull-out units, magic corners, etc. Any unit that requires a handle will be clearly identified within the Price list.

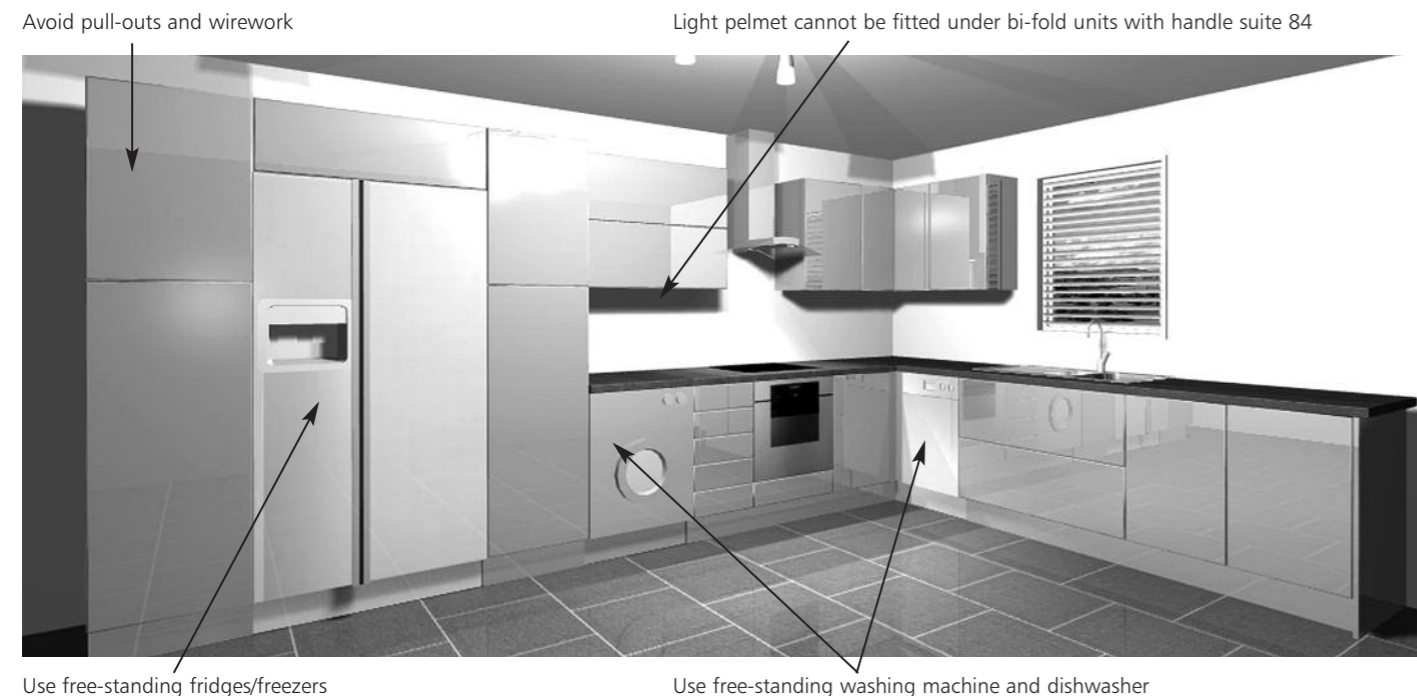

Option 2 - Integrated Appliances

The second way of designing a Contact kitchen is to order certain appliance doors and units with a face fixed handle. These are highlighted in the Price list and recommended handle suites are 2, 73, 78.

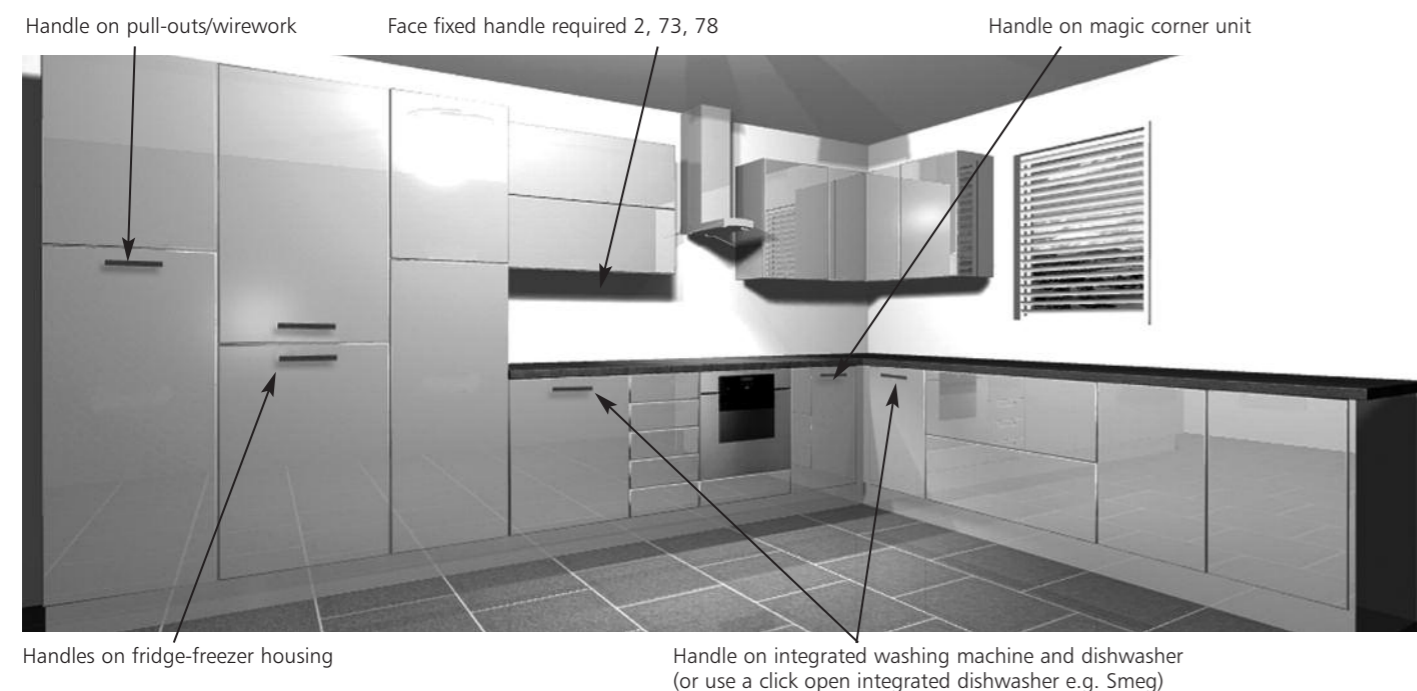

Option 3 - Aluminium Extrusion

The third way of designing a Contact kitchen is to fit worktop extrusion to the base units which lifts the worktop by 30mm. 30mm vertical extrusions are used between tall units.

Certain appliance doors and units need to be ordered with handle Suite 84 with the extrusions providing a recess which allows access to the handle.

(Note: Curved base units cannot be fitted with the worktop extrusion.)

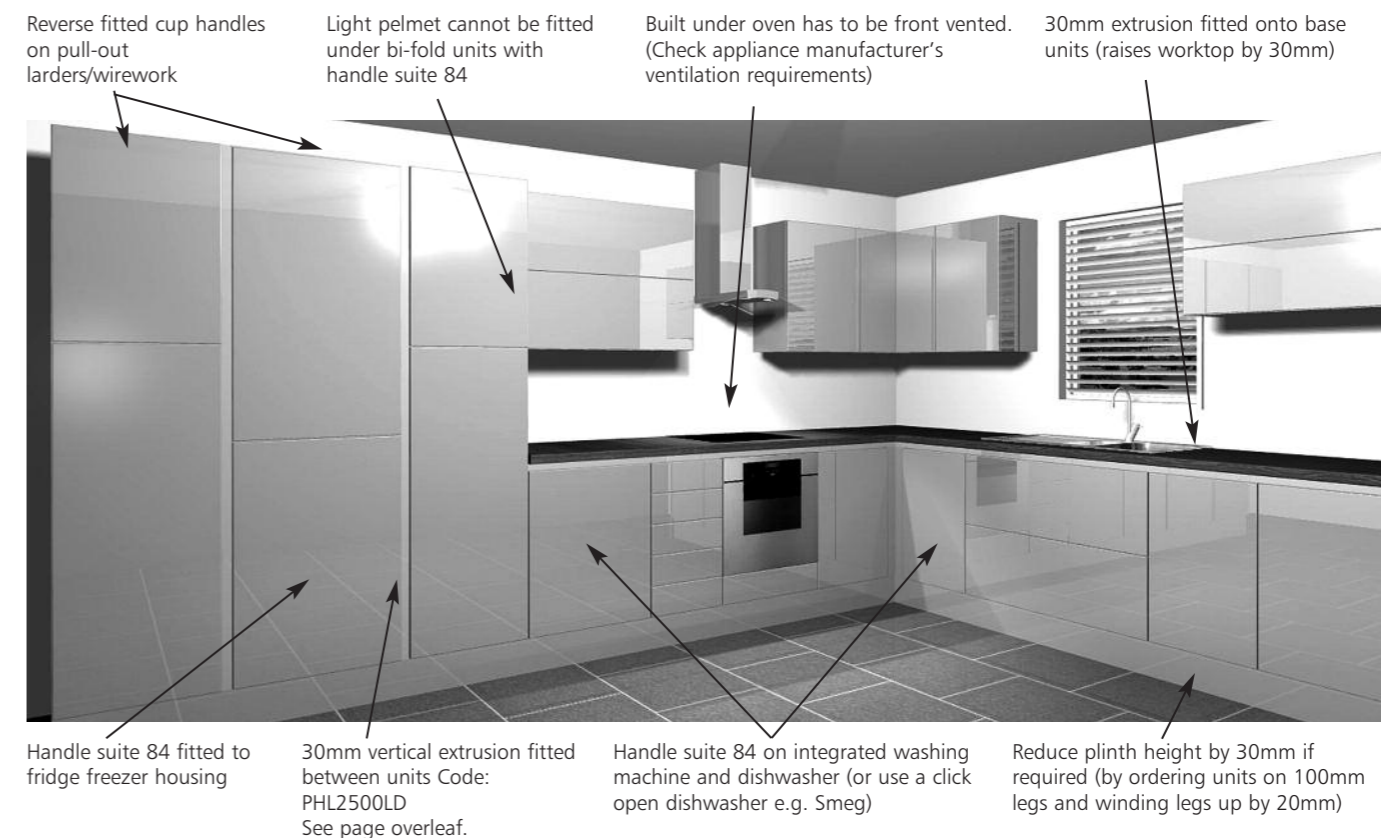

Aluminium extrusion fitted horizontally below worktop Code: PHL3500WT. See page overleaf.





Suite 84 – Units that require this handle are marked with ❖

PLEASE NOTE THE WORKTOP EXTRUSION CANNOT BE USED WITH CURVED UNITS.

CHIPPENDALE CONTACT

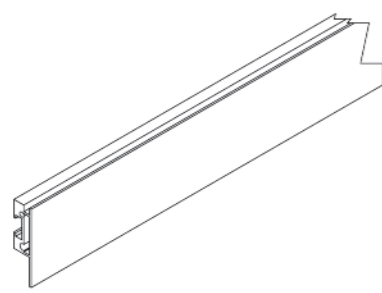
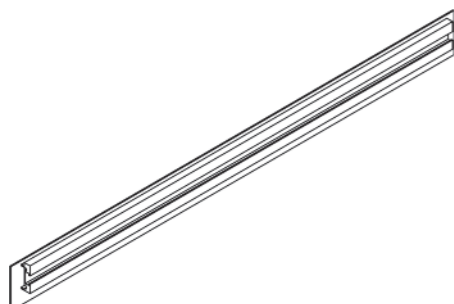
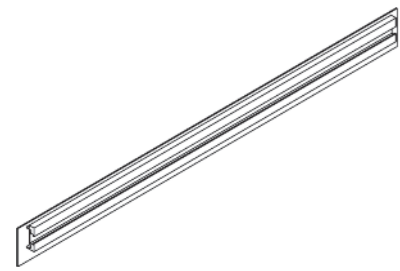
CONTACT HANDLELESS EXTRUSION KITS

Model/Description	Product Code	Price
<p>Contact Worktop Extrusion Kit</p>  <p>Kit includes: 1 x 3500mm Extrusion 10 x Fixing clips 5 x Worktop spacers 1 x roll of sealing strip 6000mm</p>	PHL3500WT	£106
<p>Contact Worktop Extrusion Kit – End Piece</p>  <p>VAT Charged at Standard Rate For use at the end of a run of base units – trim one end as required</p> <p>For use on island units where an 890mm add-on panel is used at each end</p>	PHL829END	£27
<p>Contact Worktop Extrusion Kit – Island End Piece</p>  <p>For use on island units where a 596mm add-on panel is used at each end</p>	PHL555END	£21
<p>Contact Vertical Extrusion Kit</p>  <p>Kit includes: 1 x 2500mm extrusion 8 x Fixing clips 4 x Spacers</p>	PHL2500LD	£85

EXTRUSION FIXING / WORK SPACES / DRAWER RUNNERS

Contact Base Unit Extrusion Fixing

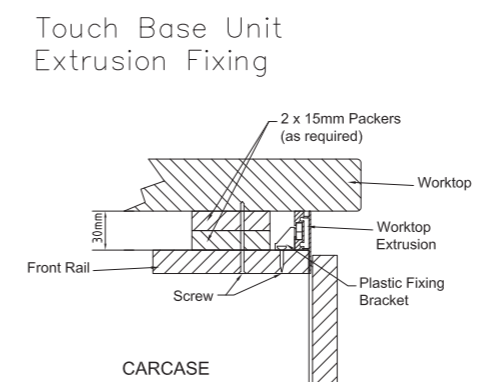

Contact Tall Unit Extrusion Fixing

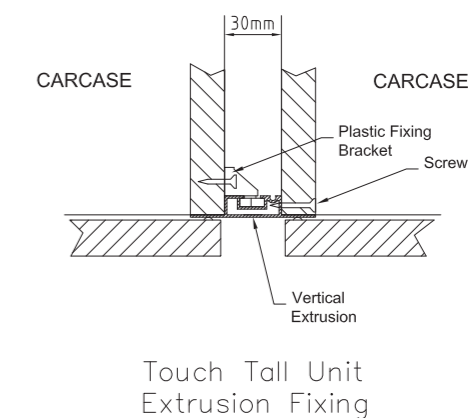

Contact Worktop Spacers

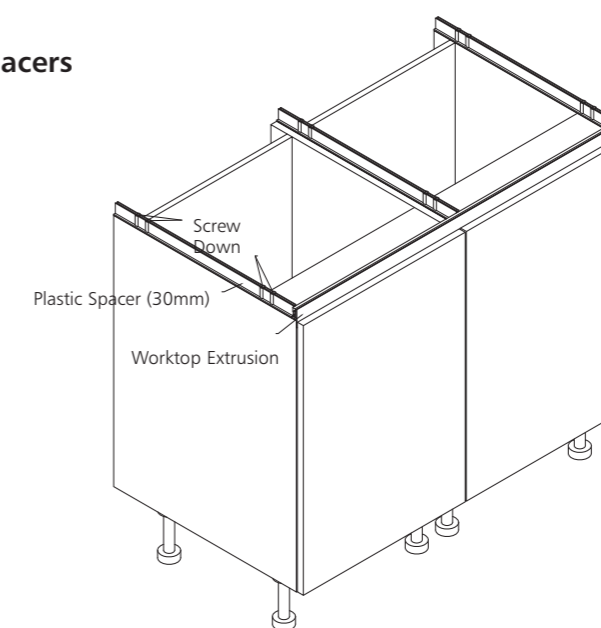

Contact Drawer Runners

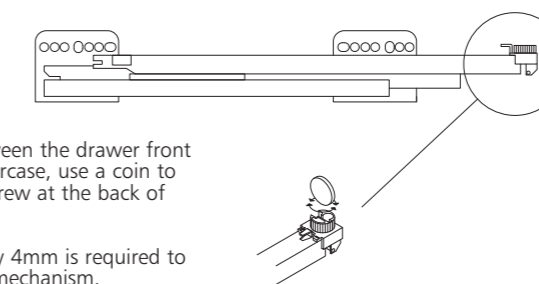

To adjust the gap between the drawer front and the front of the carcass, use a coin to turn the adjustment screw at the back of the runner.

A gap of approximately 4mm is required to activate the 'Contact' mechanism.

